

---

# TNIC ADAPTER CARD SPECIFICATIONS

## Standards

IEEE 802.2, 802.3

## Physical

### Dimensions

4.80" X 2.77" X 0.95" (122mm x 70mm x 24mm)

## MTBF

TNIC-1500T	2,300,000 hours
TNIC-1500TA2	1,660,000 hours
TNIC-1500-TF	762,000 hours
TNIC-1500- AF	762,000 hours
TNIC-1500-PCI-T	1,179,000 hours

## Environment

Temperature:	0-50°C (32° to 122° F)
Humidity	10-90%, non condensing
Altitude	0-10,000 feet

## Warranty

2 years

# TNIC Adapter Card

(TNIC-1500T, TNIC-1500TA2, TNIC-1500-TF,  
TNIC-1500-AF, TNIC-PCI-T)

7355.B

For assistance in installing, using, or maintaining the TRANSITION Networks TNIC Adapter Card, contact TRANSITION Networks Technical Support at:

**(800) 260-1312**

or contact your local distributor.

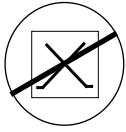

**CAUTION: RJ connectors are NOT INTENDED FOR CONNECTION TO THE PUBLIC TELEPHONE NETWORK. Failure to observe this caution could result in damage to the public telephone network.**

Der Anschluss dieses Gerätes an ein öffentliches Telekommunikationsnetz in den EG-Mitgliedstaaten verstösst gegen die jeweiligen einzelstaatlichen Gesetze zur Anwendung der Richtlinie 91/263/EWG zur Angleichung der Rechtsvorschriften der Mitgliedstaaten über Telekommunikationsendeinrichtungen einschliesslich der gegenseitigen Anerkennung ihrer Konformität.

### Compliance Information

UL Listed

C-UL Listed (Canada)

CISPR/EN55022 Class A

### FCC Regulations

This equipment has been tested and found to comply with the limits for a class A digital device, pursuant to part 15 of the FCC rules. These limits are designed to provide reasonable protection against harmful interference when the equipment is operated in a commercial environment. This equipment generates, uses, and can radiate radio frequency energy and, if not installed and used in accordance with the instruction manual, may cause harmful interference to radio communications. Operation of this equipment in a residential area is likely to cause harmful interference, in which case the user will be required to correct the interference at the user's own expense.

### Canadian Regulations

This digital apparatus does not exceed the Class A limits for radio noise for digital apparatus set out on the radio interference regulations of the Canadian Department of Communications.

### European Regulations

#### Warning

This is a Class A product. In a domestic environment this product may cause radio interference in which case the user may be required to take adequate measures.

### Copyright Restrictions

© 1995, 1996 TRANSITION Networks Inc.

All rights reserved. No part of this work may be reproduced or used in any form or by any means – graphic, electronic, or mechanical – without written permission from TRANSITION Networks Inc.

### Trademark Notice

All registered trademarks and trademarks are the property of their respective owners.

## 10Base2 Cable Specifications

The physical characteristics of the 10Base2 cable must meet or exceed IEEE 802.3 10Base2 specifications.

### Cable Characteristics:

Cable type:	Stranded Coaxial RG58 (ThinNet)
Impedance:	50 $\Omega$ @ 10 MHz
Mutual Capacitance:	24 pF/ft $\pm$ 20% @ 10 MHz
<b>Maximum Cable Length:</b>	185 meters (610 feet)
<b>Maximum number network connections:</b>	30
<b>Minimum distance between connections:</b>	0.5 meters (1.6 feet)

**Terminate 10Base2 cable at one end using a 50 ohm terminator and at the other end using a 50 ohm terminator grounded to earth ground.**

## 10BaseT Cable and Connector Specifications

The physical characteristics of the 10BaseT cable must meet or exceed IEEE 802.3 10BaseT specifications.

### 10BaseT Cable Characteristics:

Category 3 wire or better is required; category 5 wire is recommended. Either shielded twisted pair (STP) or unshielded twisted pair (UTP) can be used. **DO NOT USE FLAT OR SILVER SATIN WIRE.**

#### Category 3:

Gauge	24 to 22 AWG
Attenuation	28 dB/1000' @ 10 MHz
Differential Characteristic Impedance	100 $\Omega$ $\pm$ 10% @ 10 MHz

#### Category 5:

Gauge	24 to 22 AWG
Attenuation	20 dB/1000' @ 10 MHz
Differential Characteristic Impedance	100 $\Omega$ $\pm$ 10% @ 10 MHz

**Maximum Cable Length:** 100 meters (330 feet)

### 10BaseT Connector Characteristics:

The two active pairs in a 10BaseT network are pins 1 & 2 and pins 3 & 6. Use only dedicated wire pairs (such as blue/white & white/blue, orange/white & white/orange) for the active pins. 10BaseT cable for unlike devices (such as hub to terminal device) must be configured as straight through; 10BaseT cable for like devices (such as hub to hub or terminal device to terminal device) must be configured as crossover.

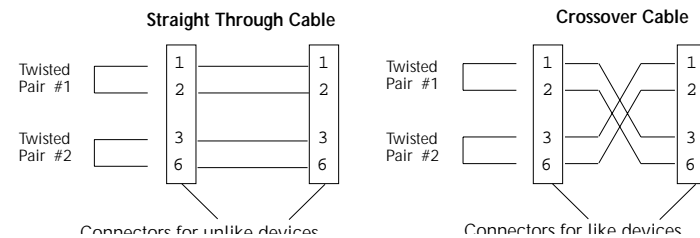

# ETHERNET CABLE SPECIFICATIONS

Maximum number of terminal devices on Ethernet network: 1024

## 10Base5 Cable and Connector Specifications

The physical characteristics of the 10Base5 cable must meet or exceed IEEE 802.3 10Base5 specifications.

### 10Base5 Cable Characteristics:

Cable type:	RG8 Solid Coaxial (ThickNet)
Impedance:	50 $\Omega$ @ 10 MHz
Capacitance:	26pF/ft
<b>Maximum Cable Length:</b>	500 meters (1650 feet)
<b>Maximum number network connections:</b>	100
<b>Minimum distance between connections:</b>	2.5 meters (8.2 feet)

Terminate 10Base5 cable at one end using a 50 ohm terminator and at the other end using a 50 ohm terminator grounded to earth ground.

## AUI Cable and Connector Specifications

The cable is a special 4-pair individually shielded with an overall braided shield.

<b>Maximum AUI Cable Length:</b>	50 meters (165 feet)
----------------------------------	----------------------

### AUI Connector Characteristics:

AUI Port:	Male DB-15 with locking posts.		
AUI Connection:	Cable shell must be grounded.		
Connector Legend:	1 Logic Ref.	6 Power Return	11 Logic Ref
	2 Collision+	7 N/C	12 Receive
	3 Transmit+	8 Logic Ref.	13 Power
	4 Logic Ref.	9 Collision--	14 Logic Ref.
	5 Receive+	10 Transmit-	15 N/C

## 10BaseFL Cable and Connector Specifications

The physical characteristics of the 10BaseFL cable must meet or exceed IEEE 802.3 10BaseFL specifications.

### 10BaseFL Cable Characteristics:

Fiber Optic Cable Recommended:	62.5/125 $\mu$ m multimode fiber
Optional:	100/140 $\mu$ m multimode fiber
	85/125 $\mu$ m multimode fiber
	50/125 $\mu$ m multimode fiber
Fiber Optic Transmitter Power:	Average power: -15.0 dBm
	Peak power: -12.0 dBm $\pm$ 1dBm
Fiber Optic Receiver Sensitivity:	Average sensitivity: -27.4 dBm
	Bit error rate: $\leq 10^{-10}$

<b>Maximum Cable Length:</b>	2000 meters (6500 feet)
------------------------------	-------------------------

### 10BaseFL Connector Characteristics:

ST type connectors (SMA type available upon request)

## Table of Contents

<b>1 INTRODUCTION</b>	<b>1</b>
TNIC Adapter Cards/Software	1
The TNIC Family of Adapter Cards	2
LED Status Indicators	3
TNIC Adapter Cards INSTALL Software	4
INSTALL Main Window	5
INSTALL Automatic Card Configuration Window	7
INSTALL Custom Card Configuration Window	8
INSTALL TNIC Driver Installation Window	9
INSTALL Diagnostics Window	10
<b>2 SITE CONSIDERATIONS</b>	<b>11</b>
<b>3 INSTALLATION</b>	<b>12</b>
Unpacking TNIC Adapter Card	12
Setting Jumpers on 1500-x	13
Installing TNIC Adapter Card in PC	16
Installing Configuration and Driver Software in PC	17
Connecting Cable to TNIC Adapter Card	18
<b>4 OPERATION</b>	<b>22</b>
<b>5 MAINTENANCE</b>	<b>24</b>
Fault Isolation	24
Technical Support Contact	24
<b>POLICY AND PROCEDURE</b>	<b>25</b>
<b>ETHERNET CABLE SPECIFICATIONS</b>	<b>27</b>
<b>TNIC ADAPTER CARD SPECIFICATIONS</b>	<b>29</b>

# 1. INTRODUCTION

This guide is intended for the system or network administrator responsible for installing and monitoring a TRANSITION Networks TNIC Adapter Card. A working knowledge of local area network (LAN) operations, including familiarity with communications protocols used on interconnected LANs, is assumed.

## TNIC Adapter Cards/Software

The TRANSITION Networks TNIC Family of Adapter Cards (TNIC-1500T, TNIC-1500TA2, TNIC-1500-TF, TNIC-1500-AF, TNIC-PCI-T), provides an integrated hardware/software interface between a PC and various 802.3 Ethernet compliant media.

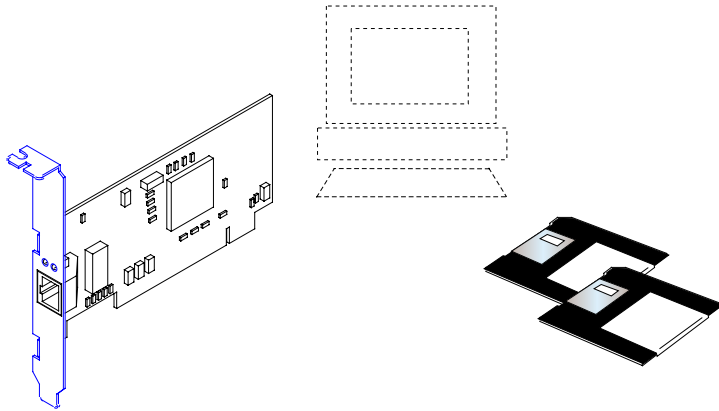

Driven by software installed in the PC in which the adapter card is installed, the TNIC Adapter Card provides connection to the following Ethernet media:

- 10BaseT
- 10Base2
- 10Base5
- 10BaseFL

TN's total liability in connection with the products and installation thereof to all persons and from all causes in the aggregate whether in contract, tort, or strict liability shall not exceed the amount paid to TN for the product directly related to the alleged damage. However, in no event shall TN have any liability to a customer or any third party with respect to a product manufactured in accordance with customer's specifications.

### C. Return Procedure

Before TN item(s) can be returned, a Credit Return Authorization (CRA), Return Material Authorization (RMA), or Material Repair Authorization (MRA) number must be obtained from TRANSITION Networks (TN) or the distributor of origin.

Locate the serial number(s) of the item(s) to be returned. From the item serial number, TN or the distributor will verify the return status and provide the appropriate number to the End User. The three types of return numbers are listed below:

- A Credit Return Authorization (CRA) number can only be requested from your distributor. This CRA number will only be issued to distributors for item(s) within 90 days from the original ship date. Under no circumstances will a CRA number be issued directly to the End User. The return item(s) must be shipped freight prepaid, by the End User or the Distributor to TN.
- A Return Material Authorization (RMA) number can be requested from TN or your distributor. This RMA number is only issued for item(s) after 90 days from the original ship date but prior to the expiration of the warranty period. The return item(s) must be shipped freight prepaid, by the End User or Distributor, to the TN address below:

TRANSITION Networks Inc.  
6475 City West Parkway  
Eden Prairie, MN 55344 USA

TRANSITION Networks will repair or replace the unit, at its discretion, and cover the cost of the return freight to the distributor or End User who was issued the RMA number.

- A Material Repair Authorization (MRA) number can be requested from TN or your distributor. This MRA number is only issued for out-of-warranty item(s). The return item(s) must be shipped freight prepaid, by the End User, to the TN address above. The sender will be contacted by TN after the item(s) have been received, inspected, and a cost estimate of the repair has been determined. The repair charges may be billed, with approval, through your distributor or prepaid/C.O.D. basis through the End User. In either case, charges will include freight, both ways, and repair charges.

The return authorization number is only valid for 60 days from the date of issuance. Please list this number on the outside of the carton and/or packing list. Include a copy of the original invoice or packing slip to expedite processing.

### D. Restocking Fee

All returns for credit must be received in the same condition as originally shipped. If TN determines that a returned product is damaged due to improper packaging or if the item is functional and returned because of customer error, inability to use, etc., TN reserves the right to charge a minimum 15% (\$10.00 minimum per item) restocking fee, the payment of which is a condition precedent to the repair and/or return of the product.

## Policy And Procedure

### A. Limited Warranty

TRANSITION Networks (TN) warrants, for a period of two years (with the exclusion of five years for passive balun products) from the date of shipment to the original purchaser and at the original point of installation, that products of TN's design will be free from defects in materials and workmanship and in conformity with TN's specifications. TN's sole warranty with respect to products manufactured or assembled by TN in accordance with a customer's specifications is a two year warranty that such goods conform to such specifications. These warranties do not extend to goods that have been subject to alterations, misuse, accident, tampering, improper maintenance, improper installation or abuse.

THE ABOVE WARRANTY IS EXCLUSIVE AND EXTENDS ONLY TO PRODUCTS ASSEMBLED BY TN, AND TO THE EXTENT PERMITTED BY LAW, TN DOES NOT MAKE AND DISCLAIMS ALL OTHER WARRANTIES (EXCEPT TITLE), EXPRESSED OR IMPLIED, INCLUDING BUT LIMITED TO ANY WARRANTY OF DESCRIPTION, MERCHANTABILITY, FITNESS FOR A PARTICULAR PURPOSE OR NON-INFRINGEMENT AND ANY WARRANTY BASED UPON PRIOR WRITTEN OR ORAL REPRESENTATIONS REGARDING SUCH PRODUCTS MADE BY TN, ITS EMPLOYEES, AGENTS, OR REPRESENTATIVES.

### B. Limitations and Exclusions

If customer believes any goods sold hereunder are defective pursuant to the warranty and within the warranty period set forth above, the customer must notify TN within such period. TN will promptly issue a return form for such goods. Upon receipt of the form, customer is to promptly return the allegedly defective goods at customer's expense and shipped prepaid to your distributor or TN (refer to the next subsection C, Return Procedure).

No goods will be accepted for return unless a prior return form is obtained from TN, freight charges have been prepaid by customer. TN or the distributor shall, at its option, either (i) repair such goods free of charge if warranty within two years, (ii) repair such goods at a minimum of \$200 (Two Hundred dollars) per item if warranty expired, (iii) replace such goods free of charge, or (iv) accept the return of such goods and credit current price therefore to the customer.

THIS IS THE EXCLUSIVE REMEDY FOR ANY BREACH OF WARRANTY. IN NO EVENT SHALL TN BE LIABLE FOR SPECIAL, INDIRECT, INCIDENTAL OR CONSEQUENTIAL DAMAGES OF ANY KIND, WHETHER FOR BREACH OF ANY WARRANTY, FOR BREACH OR REPUDIATION OF ANY OTHER TERM OR CONDITION OF SALE, FOR NEGLIGENCE, ON THE BASIS OF STRICT LIABILITY, CONTRACT, OR OTHERWISE AND IRRESPECTIVE OF WHETHER TN IS INFORMED BY CUSTOMER OF THE POSSIBILITY OF SUCH DAMAGES IN ADVANCE OF THIS SALE.

The sole purpose of this remedy shall be to provide the customer with the replacement or repair of non-conforming goods in the manner provided here-in. This exclusive remedy shall not be deemed to have failed of its essential purpose so long as TN is willing and able to repair or replace the non-conforming goods or refund the purchase price therefore in the manner provided herein.

TN reserves the right to inspect products claimed to be defective under warranty either at the customer's location or at TN's plant. TN assumes no liability for labor charges incidental to the adjustment, service, repairing, removal or replacement of the product or other costs, or the expense of repairs made outside of its factory except when made pursuant to TN's prior written consent. All returns must be received in the same condition as the original shipment.

## The TNIC Family of Adapter Cards

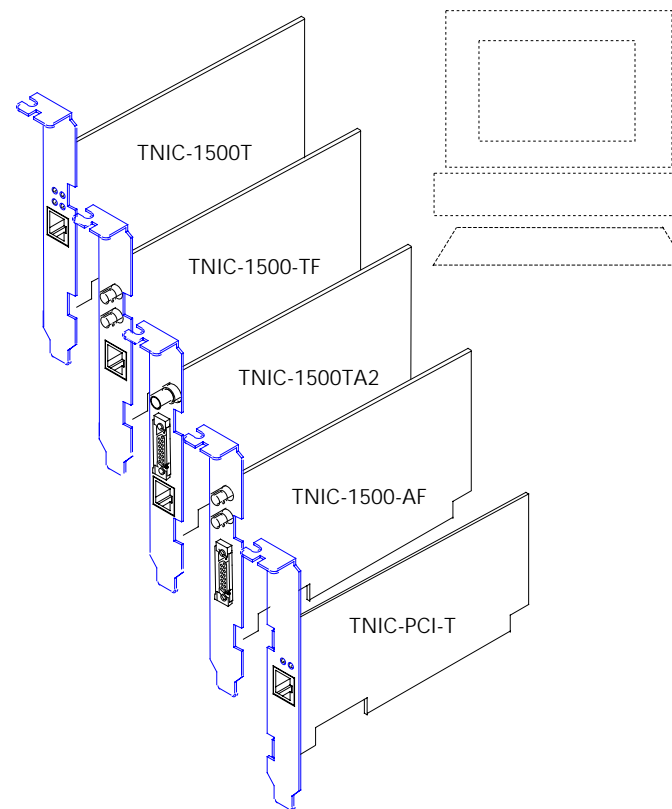

The naming convention for the TRANSITION Networks TNIC Series 1500 Adapter Cards identifies the connectors:

T = twisted pair (10BaseT)      2 = thinet (10Base2)  
A = AUJ (connects to 10Base5)      F = fiber (10BaseFL)

In installations of TNIC Adapter Cards with more than one media connector, only one connector (site-selectable using jumpers) can be active at a time.

## LED Status Indicators

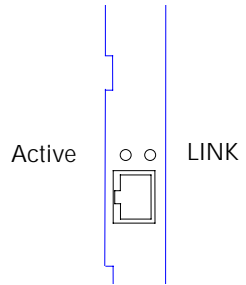

### TNIC PCI Card

- LINK Illuminated when link is established.
- Active Flashes during data transmission and reception.

### TNIC 1500T Card

- LINK Illuminated when link is established.
- Transmit Flashes during data transmission.
- Receive Flashes during data reception.
- Polarity OK Illuminated when 10BaseT connection is established.

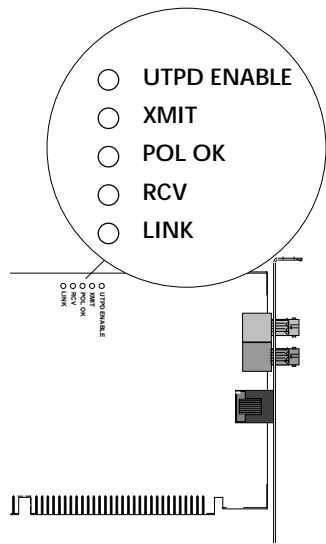
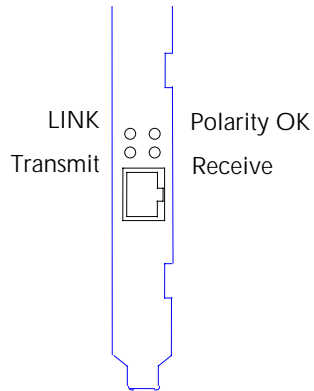

### TNIC 1500n Cards

- UTPD ENABLE Illuminated when AUI connection is established.
- XMIT Flashes during data transmission.
- POL OK Illuminated when 10BaseT connection is established.
- RCV Flashes during data reception.
- LINK Illuminated when link is established.

## 5. MAINTENANCE

**WARNING: DO NOT, UNDER ANY CIRCUMSTANCES, attempt to repair the TNIC Adapter Card. Failure to observe this warning could result in personal injury or death from electrical shock.**

NOTE: Failure to observe the above warning will immediately void the warranty.

### Fault Isolation

If two network devices fail to communicate through the TNIC Adapter Card, consider the following:

- Are the LEDs described in the previous section functioning properly?
- Do network devices have Link Integrity enabled?
- Do network devices communicate when the TNIC Adapter Card is not installed between them?
- Is flat or "silver satin" wire used in site internal wiring?
- Are internal wiring patch cords, punch down blocks, and wall jacks properly pinned or configured?
- Is the AUI cable unbroken and properly connected?
- Are network interface cards properly configured?

### Technical Support Contact

For assistance in fault isolation and in maintaining the TNIC Adapter Card, contact:

Technical Support (800) 260-1312

or your local distributor.

## TNIC 1500n Cards

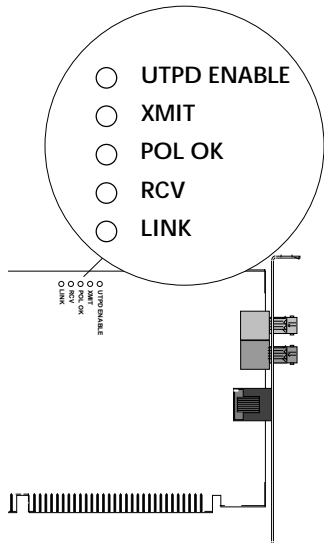

UTPD ENABLE	Illuminated when AUI connection is established.
XMIT	Flashes during data transmission.
POL OK	Illuminated when 10BaseT connection is established.
RCV	Flashes during data reception.
LINK	Illuminated when link is established.

## TNIC Adapter Card INSTALL Software

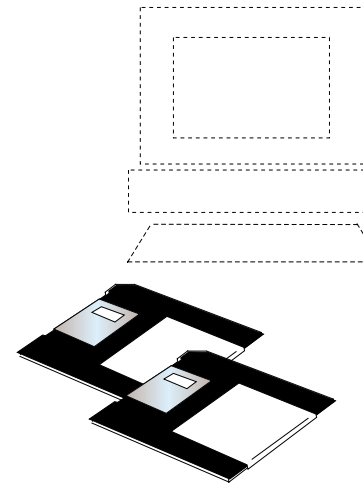

TRANSITION Networks' INSTALL software, shipped as a set of two **Universal TNIC Driver Disks** (#7210), provides a graphical interface for configuring the TNIC Adapter Card and for installing a software driver. (Disk 2 also provides detailed documentation that may be required for complex driver installations.)

The INSTALL utility automatically scans the system bus (ISA, VL, or PCI) to identify which TNIC

adapter card is present, then configures the adapter card and installs driver software on the system hard drive.

The following drivers can be installed using the INSTALL utility:

- Novell NetWare DOS ODI client driver
- NDIS 2.01 driver
- Packet driver

For other environments, see the appropriate driver installation instructions in the MS-Word file: TNIC.DOC on Disk 2 of the **Universal TNIC Driver Disk**. Using the instructions provided, the following drivers can be installed through the INSTALL utility or can be installed manually at the command-line prompt:

- NDIS 3.x driver
- SCO Unix LLI driver
- Novell UnixWare DLPI driver
- SunSoft Solaris driver

## INSTALL Main Window

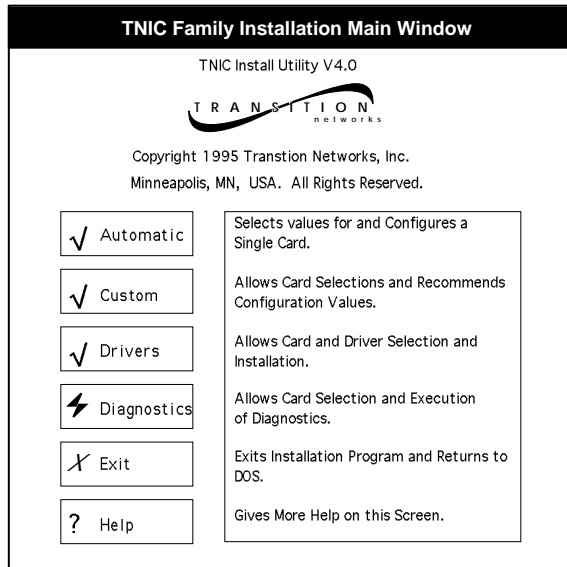

Before the Main window appears, the utility searches for a TNIC adapter card in the system. If one is not found, an error screen is displayed telling the user to install the adapter card before using the utility. If only one Ethernet card is found and a conflict-free configuration is determined, the Automatic, Custom, and Drivers buttons are enabled. If more than one card is found or if the configuration has conflicts, only the Custom and Drivers buttons are enabled.

Depending on the TNIC adapter card (and the configuration buttons enabled), the utility allows the user to view and modify the I/O Address, IRQ Level, and DMA Channel settings and determines settings that will configure the TNIC card to be compatible with other card settings in the system.

If multiple adapter cards are present, the INSTALL utility permits the user to select each adapter card in turn and to modify the adapter card configuration settings as needed.

## 4. OPERATION

The TNIC Adapter Card requires no intervention beyond occasionally monitoring the Power and Link/Transmit LEDs.

### TNIC PCI Card

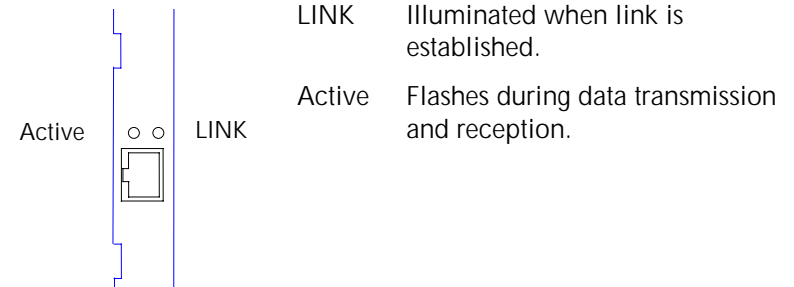

### TNIC 1500 T Card

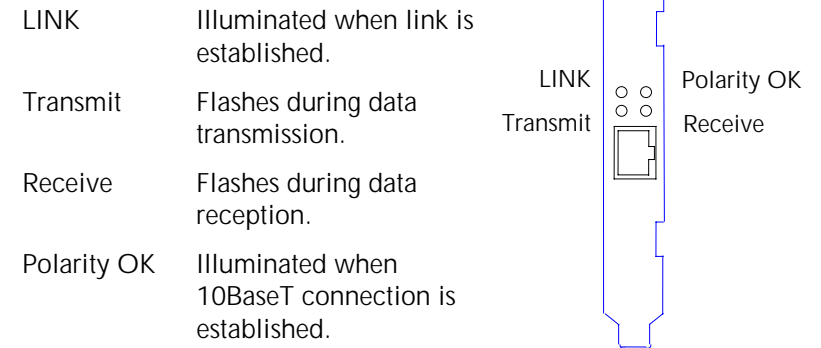

## Twisted Pair Connector/10BaseT Connection

To connect 10BaseT Cable to TNIC Adapter Card RJ-45 connectors:

1. Locate or build 10BaseT cables with the following characteristics:
  - 803.2 compliant (See page 14)
  - correct (straight through) cable configuration for site installation (See page 6)
  - male RJ-45 plug connectors installed at both cable ends.
2. Connect male RJ-45 plug connector at one end of 10BaseT cable to TNIC Adapter Card RJ-45 jack connector.
3. Connect male RJ-45 plug connector at other end of 10BaseT cable to DCE hub RJ-45 jack connector (using **straight through** cable orientation)

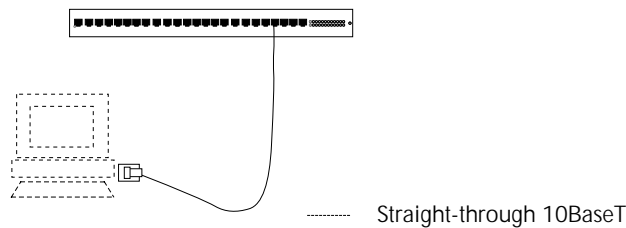

**Automatic** The Automatic selection displays system compatible settings.

**Custom** The Custom selection displays the current TNIC card's settings and allows the user to choose system compatible settings.

**Drivers** The Drivers selection of the INSTALL utility is used to install the software drivers. Depending on the operating system, the utility allows the user to select a default path or specify the destination.

**Diagnostics** The Diagnostics selection of the INSTALL utility is used to determine TNIC adapter card installation failures. The utility will determine: (1) if the system conflicts with the TNIC adapter card's settings and (2) if the TNIC adapter card is connected to the Local Area Network (LAN).

**Exit** The Exit selection of the INSTALL utility quits the program.

**Help** The Help selection of the INSTALL utility displays screen specific information to aid in making selections. The following three help levels are always available:

<b>Button Help</b>	Displays button and field description text
<b>F1 Help</b>	Displays information about a selected field.
<b>Dynamic Help</b>	Displays a one-line message at the bottom of the screen when the mouse cursor passes over the selectable item.

Although the INSTALL utility supports a mouse, a key map is provided below to navigate through the utility without a mouse.

Key	Function
ESC	Exit the configuration or help screen
F1	Help
Tab	Move the cursor to the next position
Left/Right arrows	Move the cursor left or right
<Shift> Tab	Move the cursor to the previous position
Up/Down arrows	Move the cursor up or down
ENTER	Select (Highlight)
Space bar	Select (Highlight)
<Alt> Hot Keys	Select (Functions)

## INSTALL Automatic Card Configuration Window

Card Name	Bus Type	Ethernet Address

I/O Address	<input type="text"/>
DMA Channel	<input type="text"/>
IRQ Level	<input type="text"/>
Boot ROM Address	<input type="text"/>

Selections

Configure	- To Accept Proposed Values and Configure Card
Drivers	- To Select and Install Drivers
Main	- To Return to TNIC Family Installation Main Window

✓ Configure   ✓ Drivers   ↻ Main   ✕ Exit   ? Help

The INSTALL utility detects and displays the following information in the Automatic Card Configuration Window:

- Card Name
- Bus Type
- Ethernet Address
- DMA Channel (default)
- IRQ Level (default)
- Boot ROM Address
- I/O Address

The TNIC-PCI Adapter Card values are displayed at the Automatic Card Configuration Window.

Selecting Configure allows the system to accept proposed values and configure card

## Fiber Optic Connector/10BaseFL Connection

The fiber optic adapter cards provides one set of transmit (TX) and receive (RX) ST connectors to fiber optic cable.

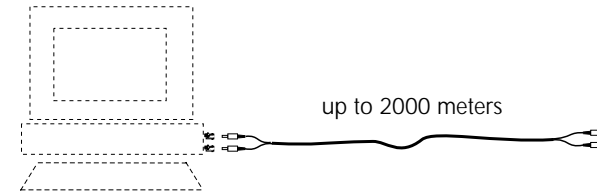

Ensure that cable installed at transmit (TX) connector of adapter card is installed at receive (RX) connector of device at other end of fiber cable; ensure that cable installed at receive (RX) connector of adapter card is installed at transmit (TX) connector of device at other end of fiber cable.

## Female AUI Connector/10Base5 or Transceiver Connection

The female AUI connector attaches to 10Base5 through an AUI drop cable or to 10Base2, 10BaseT, or 10BaseFL through a transceiver.

### Connecting 10Base5 Using AUI Drop Cable

To connect 10Base5 Cable to female AUI connector:

1. Locate or build IEEE 802.3 compliant AUI drop cable.
2. Connect AUI drop cable male DB-15 connector to the AUI connector.
3. Connect AUI drop cable female DB-15 connector to AUI port on a transceiver or media attachment unit (MAU).

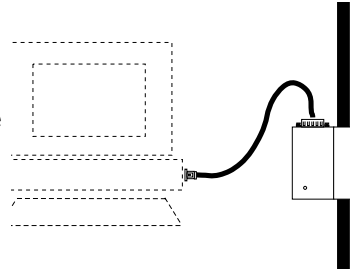

### Connecting to Network Using Transceiver

To connect to network using transceiver:

1. Locate IEEE 802.3 compliant transceiver with male AUI DB-15 connector and correct network media connector.
2. Connect transceiver male AUI DB-15 connector to the 8-Port 10BaseT female AUI connector.
3. Connect transceiver network media connector to the network media.

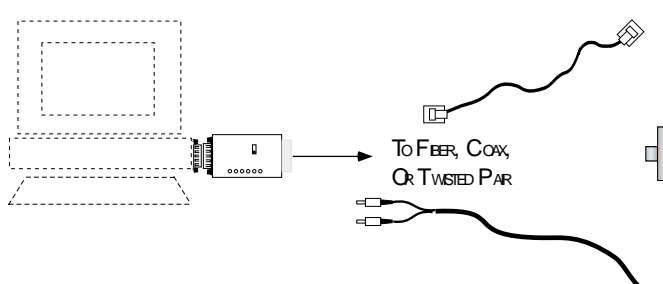

## INSTALL Custom Card Configuration Window

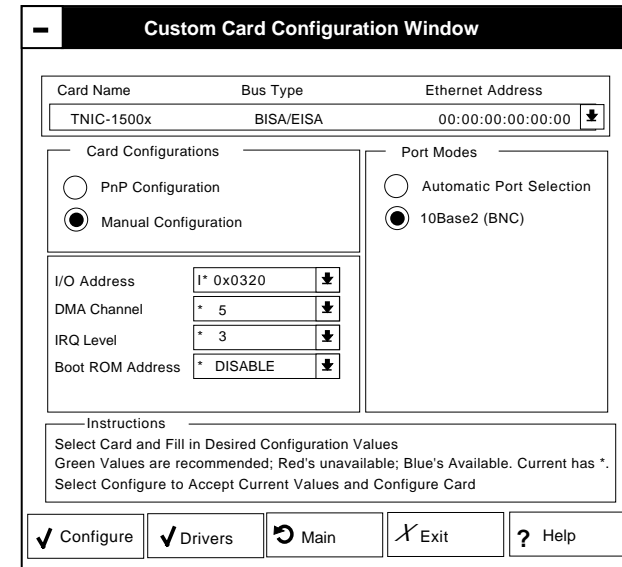

Card Name	Bus Type	Ethernet Address
TNIC-1500x	BISA/EISA	00:00:00:00:00:00

Card Configurations

PnP Configuration  
 Manual Configuration

Port Modes

Automatic Port Selection  
 10Base2 (BNC)

I/O Address: \* 0x0320  
DMA Channel: \* 5  
IRQ Level: \* 3  
Boot ROM Address: \* DISABLE

Instructions  
Select Card and Fill in Desired Configuration Values  
Green Values are recommended; Red's unavailable; Blue's Available. Current has \*.  
Select Configure to Accept Current Values and Configure Card

Configure Drivers Main Exit Help

The INSTALL utility detects and displays the following information in the Custom Card Configuration Window:

- Card Name
- Bus Type
- Ethernet Address
- Card Configuration
- Port Mode
- I/O Address
- DMA Channel (default)
- IRQ Level (default)
- Boot ROM Address

The TNIC-1500x adapter cards require the user to set the appropriate jumpers on the adapter card. After setting the jumpers and inserting the card, the user must enter the I/O address, DMA Channel, and IRQ Level in the Custom Card Configuration Window. The INSTALL utility will not determine the actual settings for the adapter card but instead will display the default values. The displayed values and the actual values must match.

## INSTALL TNIC Driver Installation Window

Card Name	Bus Type	Ethernet Address
*TNIC-PCI	PCI	00:00:00:00:00:00

Device Driver Selection  
Novell DOS ODI Client Driver

Automatic Port Selection  
A:\NOVELL\WKSTN\DOSODI

Automatic Port Selection  
C:\Netware

Instructions

1. Select the TNIC Card from Card List.
2. Select the Device Driver from the Device Driver Selection
3. Modify the Driver Paths as needed.
4. Select Install to accept the selections and install the driver.

Buttons: Install, Main, Exit, Help

The TNIC Driver Installation Window can be used to install the following drivers:

- Novell NetWare DOS ODI client driver
- NDIS 2.01 driver
- Packet driver

NOTE: Some drivers must be installed using the Network Operating System's OEM installation guidelines.

A driver may be installed by selecting the driver and specifying the destination directory. Select "Install" to copy the driver to the system hard drive.

NOTE: When INSTALL installs a device driver, sample CONFIG.NET, AUTOEXEC.NET, and PROTOCOL.INI or NET.CFG files are created. The user may use these files as examples to modify the system's CONFIG.SYS and AUTOEXEC.BAT files.

## Connecting Cable to TNIC Adapter Card

Connections between installed TNIC Adapter Card and hub include:

- BNC Connector/10Base2
- Female AUI Connector/10Base5 or transceiver
- RJ Connector/10BaseT
- ST TX/RX Connectors/10BaseFL

### BNC Connector/10Base2 Connection

Verify that coax cables are terminated properly at both ends. (In a coax thinnet installation, the first and last device in a daisy-chain must be terminated with a 50 ohm terminator.)

Verify that the 10Base2 segment is grounded to "earth ground".

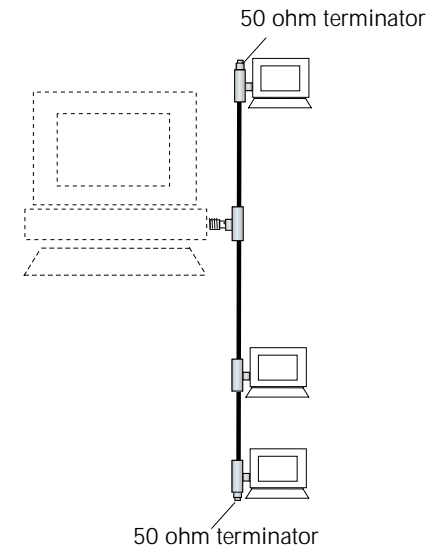

## Installing Configuration and Driver Software

To install the card configuration and driver software:

1. Make sure HIMEM.SYS is present in the CONFIG.SYS file.
2. Insert Disk 1 of the TRANSITION Networks Universal TNIC Driver Disk into the floppy drive.

NOTE: To run INSTALL faster, copy the disk contents to a temporary directory on the system hard drive.

3. Change the directory to the drive and path where the INSTALL utility is located. At the prompt, type:

```
install.exe
```

Then press <Enter>.

If the pcnet.txt file is corrupt, the following error message will be displayed:

```
"The tnic.txt file is an incompatible
version. Please contact a TRANSITION
Networks sales representative to receive
the correct version."
```

4. Follow the direction on the INSTALL screens to complete the card configuration and driver installation for the TNIC adapter card.

NOTE: Depending on which TNIC adapter card is being configured, the INSTALL utility may not allow certain fields to be modified.

## INSTALL Diagnostics Window

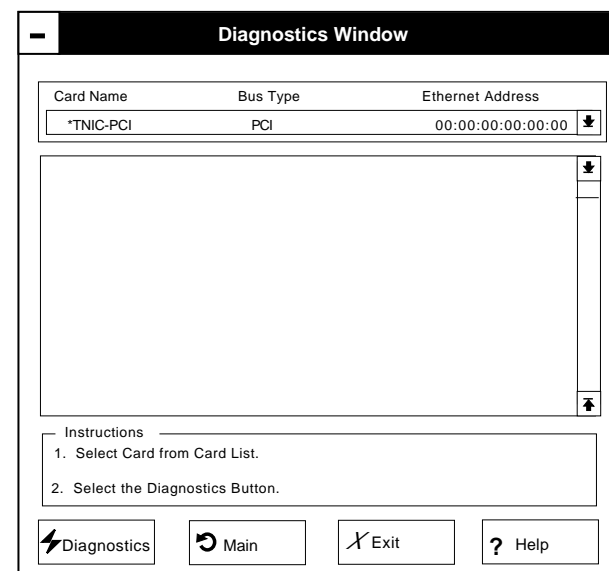

The Diagnostics Window is used to test the TNIC adapter card configuration.

The I/O Address, DMA Channel, and IRQ Level are configuration settings. A "PASS" test result means the system does not have other cards in the system set to the TNIC card's settings. A "FAIL" result means the failed setting conflicts with another card in the system. Either the TNIC adapter card's or the conflicting card's settings should be changed. Non-conflicting settings are indicated in the Automatic and Custom configuration windows as blue. A "N/A" result means the setting does not apply to the TNIC adapter card.

The loopback test determines if the computer system is able to communicate with the TNIC adapter card. A "PASS" test result means the system could write and read to the adapter card. A "FAIL" result means the system could not write and read to the adapter card.

## 2. SITE CONSIDERATIONS

The site for the TNIC Adapter Card must provide:

- Personal Computer (PC) with Microsoft DOS 3.3 or higher
- AC power outlet for PC
- Adequate ventilation
- Standard environmental conditions
- Isolation from electrical noise, including radio transmitters and broadband amplifiers, motors, high power electrical lines, or fluorescent light fixtures.

Additionally:

- The twisted pair cables should not run in the same conduit with power line cables.
- Phone lines should be separated from data cables.
- Flat or "silver satin" wires should not be used.

And:

- The entire installation should comply with the IEEE Ethernet 802.3 specification.
- RJ-45 connected cables should be configured as straight through according to installation requirements.

### Ensuring Straight Through 10BaseT Configuration

ALL 10BaseT cable and RJ-45 connectors on the TNIC Adapter Card are **Hub to Terminal** and must be configured as **straight through**.

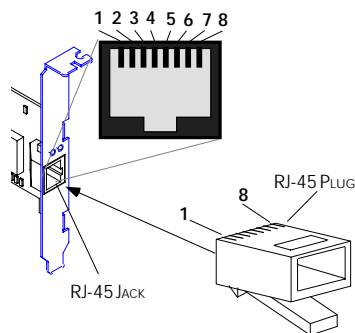

The two active pairs in a 10BaseT network are pins 1 & 2 and pins 3 & 6. Use only dedicated wire pairs (such as blue/white & white/blue, orange/white & white/orange) for the active pins.

#### Straight Through Cable at RJ-45 Plug

Hub	Terminal
RJ-45 Male	RJ-45 Male
1	1
2	2
3	3
6	6

## Installing the TNIC Adapter Card

**WARNING: DISCONNECT THE POWER CORD from the PC before installing the TNIC Adapter Card. Failure to observe this warning could result in personal injury or death from electrical shock.**

**CAUTION: Wear a grounding device and observe electrostatic discharge precautions when installing the TNIC Adapter Card. Failure to observe this caution could result in circuit board failure.**

To install the Adapter Card:

1. Place PC on table or other stable surface.
2. Remove top cover from the PC.
3. Locate card installation slot and PC bus connector.
4. From inside PC, carefully slide TNIC Adapter Card connectors through card installation slot.
5. Carefully seat TNIC Adapter Card connector in PC bus connector.

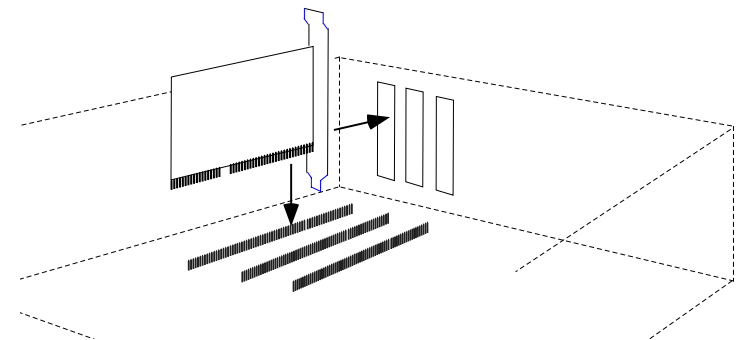

## Setting Port Selection Jumpers

PCI Card does NOT require setting port jumpers.

Select 10BaseT, AUI, 10BaseFL, and 10Base2 ports by setting the jumpers at the adapter card upper right.

### 10BaseT

Verify that jumpers on TNIC-1500T, TNIC-1500TF, or TNIC-1500TA2 are set as shown:

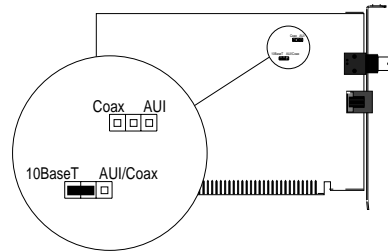

### AUI

Verify that jumpers on TNIC-1500TA2 or TNIC-1500AF are set as shown:

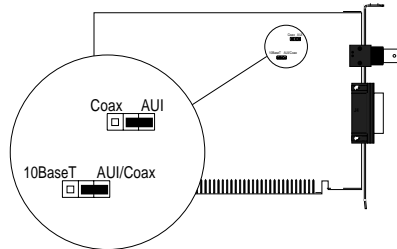

### 10BaseFL

Verify that jumpers on TNIC-1500TF or TNIC-1500AF are set as shown:

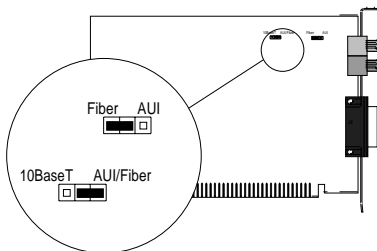

### 10Base2

Verify that jumpers on TNIC-1500T2, TNIC-1500TA2, or TNIC-1500A2 are set as shown:

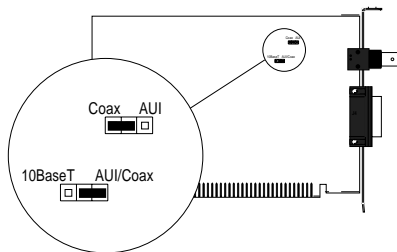

## 3. INSTALLATION

To install the TNIC Adapter Card:

- Unpack the TNIC Adapter Card.
- Set the TNIC Adapter Card jumpers, if required.
- Install the TNIC Adapter Card in the PC.
- Install Configuration and Driver Software.
- Connect Cable to the TNIC Adapter Card.
- Connect Power to the TNIC Adapter Card.

Direction is provided in the pages that follow.

### Unpacking the TNIC Adapter Card

The TNIC Adapter Card packing contents should include the following:

Item	Part Number
TNIC Adapter Card	TNIC-1500T TNIC-1500TA2 TNIC-1500-TF TNIC-1500-AF TNIC-PCI-T
Universal TNIC Driver Disk (set of 2)	7210
User's Guide	7355

# Setting TNIC Adapter Card Jumpers

NOTE: TNIC PCI Adapter Cards do NOT require setting jumpers.

## Setting Card Configuration Jumpers

TNIC Adapter Cards are shipped with the following default settings:

<b>DMA Channel Selection</b>	5
<b>Interrupt Request Selection</b>	5
<b>I/O Address Selection</b>	300h
<b>Boot PROM</b>	DISABLED

(TNIC PROMS are **ON** at the position where the jumper is installed.)

PCs normally set COM2 at IRQ3. Change the COM2 port to a different IRQ number to avoid conflict with the TNIC Adapter Card.

NOTE: BOOT PROM SIZE and BOOT PROM ENABLE are required only for diskless workstations initialized remotely by file servers.

## I/O Address Selection

JUMPERS			ADDRESSES				
Boot PROM	I/O SEL		Address PROM	RDP & RAP	Reset	IDP	Boot ROM
	1	0					
ON	ON	ON	300h-30Fh	310h-313h	314h-315h	316h-317h	C8000h-CBFFFh
ON	ON	OFF	320h-32Fh	330h-333h	334h-335h	336h-337h	CC000h-CFFFFh
ON	OFF	ON	340h-34Fh	350h-353h	354h-355h	356h-357h	D0000h-D3FFFh
ON	OFF	OFF	360h-36Fh	370h-373h	374h-375h	376h-377h	D4000h-D7FFFh
OFF	ON	ON	300h-30Fh	310h-313h	314h-315h	316h-317h	NONE
OFF	ON	OFF	320h-32Fh	330h-333h	334h-335h	336h-337h	NONE
OFF	OFF	ON	340h-34Fh	350h-353h	354h-355h	356h-357h	NONE
OFF	OFF	OFF	360h-36Fh	370h-373h	374h-375h	376h-377h	NONE

DACK	7	6	5	3
DACK7	ON	OFF	OFF	OFF
DACK6	OFF	ON	OFF	OFF
DACK5	OFF	OFF	ON	OFF
DACK3	OFF	OFF	OFF	ON

**DACK**

## DMA Channel Selection

NOTE: DACK and DRQ jumper settings must match.

DRQ	7	6	5	3
DRQ7	ON	OFF	OFF	OFF
DRQ6	OFF	ON	OFF	OFF
DRQ5	OFF	OFF	ON	OFF
DRQ3	OFF	OFF	OFF	ON

**DRQ**

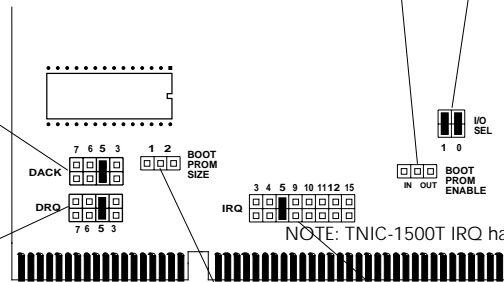

NOTE: TNIC-1500T IRQ has only jumpers 3, 4, 5 & 9.

## Boot PROM Size

SIZE	1	2
64K/128K	ON	OFF
256K	OFF	ON

## Interrupt Request Selection

IRQ	3	4	5	9	10	11	12	15
IRQ3	ON	OFF	OFF	OFF	OFF	OFF	OFF	OFF
IRQ4	OFF	ON	OFF	OFF	OFF	OFF	OFF	OFF
IRQ5	OFF	OFF	ON	OFF	OFF	OFF	OFF	OFF
IRQ9	OFF	OFF	OFF	ON	OFF	OFF	OFF	OFF
IRQ10	OFF	OFF	OFF	OFF	ON	OFF	OFF	OFF
IRQ11	OFF	OFF	OFF	OFF	OFF	ON	OFF	OFF
IRQ12	OFF	OFF	OFF	OFF	OFF	OFF	ON	OFF
IRQ15	OFF	OFF	OFF	OFF	OFF	OFF	OFF	ON